

THIS DRAWING IS UNPUBLISHED. RELEASED FOR PUBLICATION
 © COPYRIGHT BY TYCO ELECTRONICS CORPORATION. ALL RIGHTS RESERVED.

LOC		DIST		REVISIONS			
P	LTR	DESCRIPTION	DATE	DWN	APVD		
C1		REV PER EC OK40-0378-01	02NOV01	RV	MT		

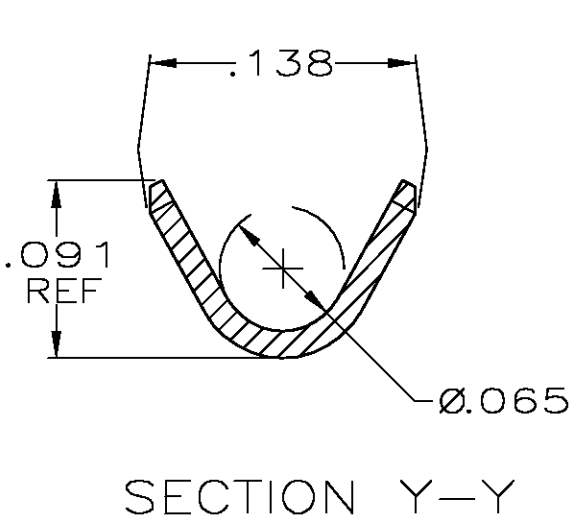
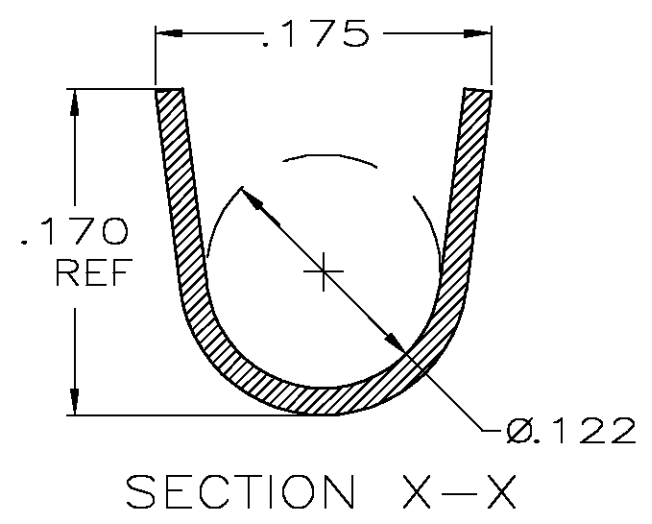
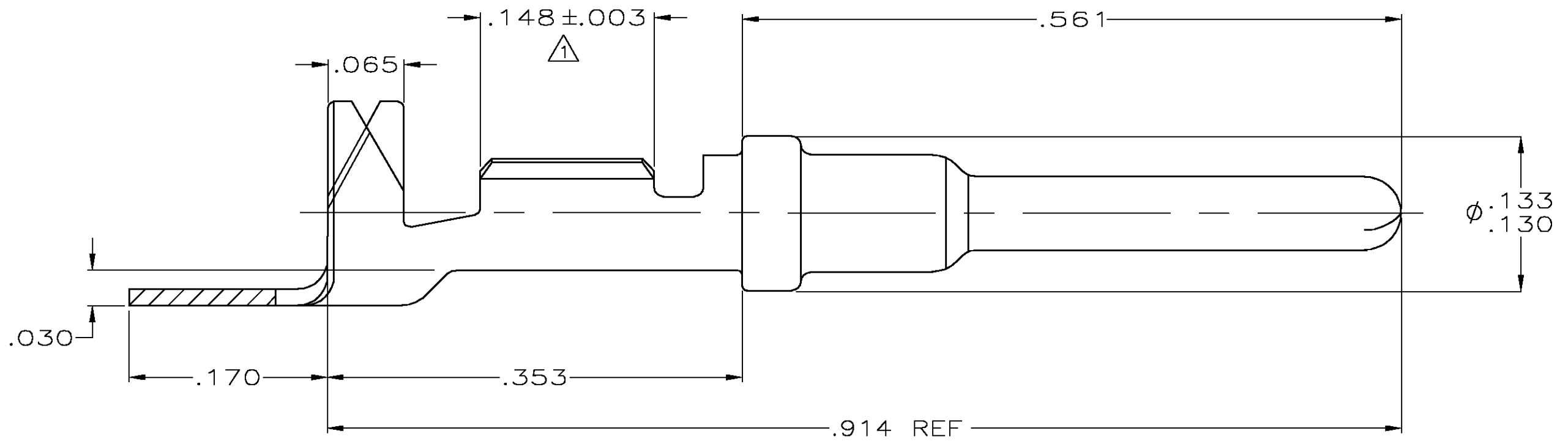
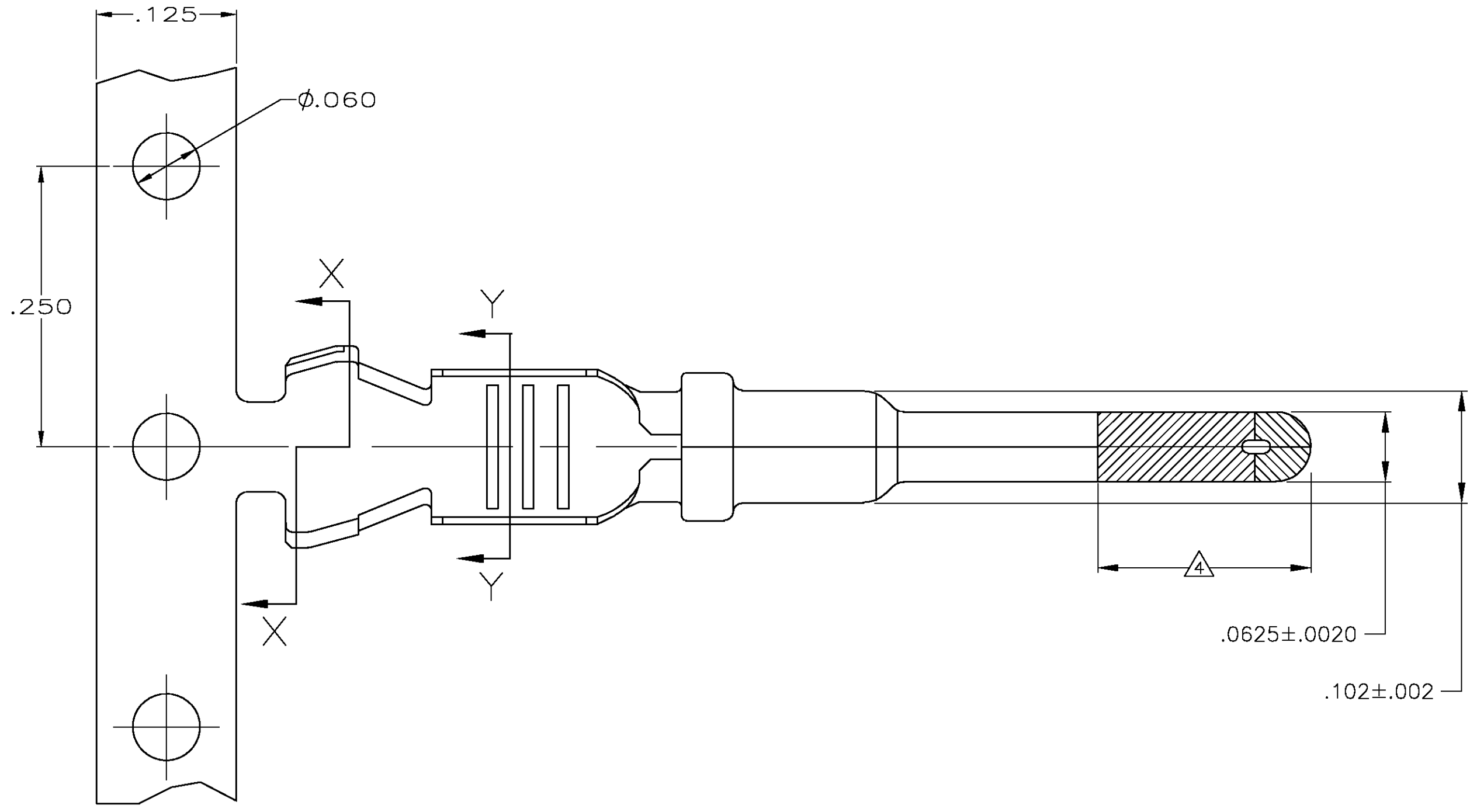

- △ FINISH : PLATE 0.000100-0.000200 THK TIN IN LOCALIZED TIN PLATE AREA, ALL OVER 0.000040-0.000080 THK NICKEL.
- 2. CONTACT WILL BE LUBED WITH LUBRICANT PER AMP P/N 22014-4.
- 3. WIRE RANGE: 20-18 AWG WITH INSULATION DIAMETERS OF 0.089 - 0.131 INCHES.
- △ PLATE 0.000030 MIN THK SELECT GOLD IN LOCALIZED PLATE AREA.

△ 1	776349-3
△ 1 △ 4	776349-1
FINISH	PART NUMBER

THIS DRAWING IS A CONTROLLED DOCUMENT.		DWN	P. YEAGER	22FEB00	Tyco Electronics Corporation Harrisburg, PA 17105-3608							
DIMENSIONS: INCHES		CHK	W. LONG	22FEB00								
TOLERANCES UNLESS OTHERWISE SPECIFIED:		APVD	W. LONG	22FEB00								
0 PLC ± - 1 PLC ± - 2 PLC ± .02 3 PLC ± .005 4 PLC ± - ANGLES ± - FINISH -		NAME	PIN CONTACT									
MATERIAL	0.014 THK.CU.ALLOY	PRODUCT SPEC	-		SIZE	A2	CAGE CODE	00779	DRAWING NO	C=776349	RESTRICTED TO	-
		APPLICATION SPEC	-		SCALE	10:1	SHEET	1	OF	1	REV	C1
		WEIGHT	-		CUSTOMER DRAWING							

776349